

OILSPY

01/ MEMBRANE (ref. 1639)

Polymer membrane for floating hydrocarbons detection

The membrane is the sensor of the **OILSPY** hydrocarbons detector.



When the membrane comes into contact with a thin layer of hydrocarbons floating on the surface of the water, it dissolves, releasing the upper axis and triggering an alarm. It was developed by NEREIDES and the French Institute of Petroleum (IFP).

Specifications

- High technology polymer membrane, stable to natural atmospheric influences.
- Recommended operating time: 6 months.
- Delivered in a 10 conditioned membranes pack.
- Storage time in its package hermetically closed: 1 year.

➔ Stocking conditions: protected from light, humidity and hydrocarbons, between 10 and 30°C.

Position of the membrane in water*

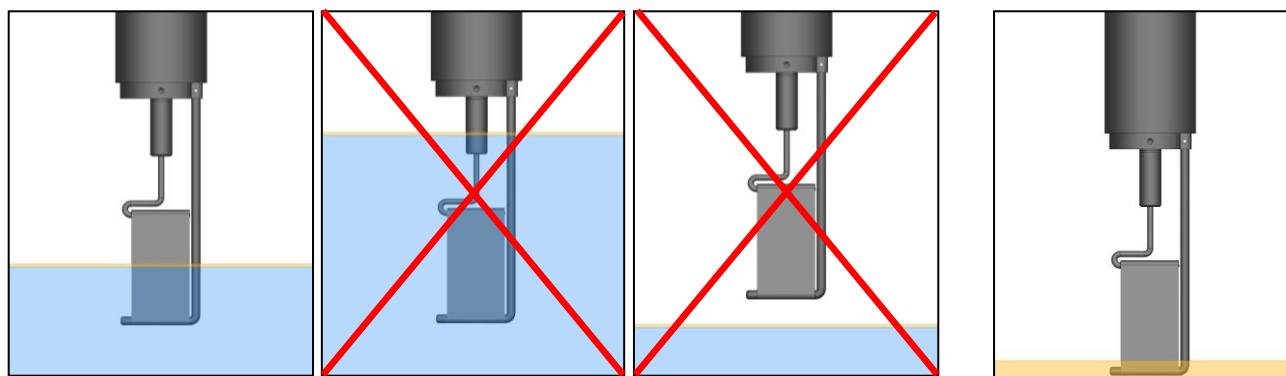

* For floating hydrocarbons detection

* For hydrocarbons detection without water

Reaction time of the membrane

⇒ Time for membrane rupture under a normal tension of about 150 g at 20°C

⇒ **Oil spill detection limit : 0.1 mm thick minimum**

○ Super grade petrol	4 sec
○ Kerosene	26 sec
○ Crude oil	2 to 13 min
○ Diesel and domestic fuel	2 to 3 min
○ Iso-octane	1 min 30 sec
○ Benzene	5 sec
○ Toluene	7 sec
○ Xylene	10 sec
○ Pentane	6 sec
○ Styrene	15 sec
○ Naphta	5 sec
○ Octyl Acetate	48 sec
○ Methyl Methacrylate	13 sec
○ Acetone	10 sec
○ Acetone/Water (50/50)	7 min
○ Hexyl Alcohol	1h50 min
○ Nonanol-5 (alcohol in C9)	1h40 min
○ Dioctylphtalate	50 min
○ B-picoline	30 sec
○ Sewage oil	1h15 min
○ Alcohol CI to C4	6h30 min
○ Dimethylacetamide	0h50 min

Chloric solvents

○ Allyl Chloride	8 sec
○ 1,1 or 1,2 Dichloroethylene	5 sec
○ Chloroform	10 sec
○ 1,2 Dichloroetene	5 sec
○ Trichloroethylene	10 sec
○ 1,1,2 Trichloroetene	10 sec

➤ Please note that chloride solvents are heavier than water. The surface device can detect their presence only if it is immersed in a way it can be in contact with them (cf sheet n° 08, Varinivo).

Membrane not sensitive

- Heavy fuel oil n° 2 normal
- Heavy fuel oil n° 2 low sulphur content
- New lubricant oil
- Pyridine/ water (50/ 50)
- Ethylene Glycol

⇒ These data are only given as indications. They are not contractual.

Mounting of the membrane on Oilspy Standard

